

scott simons architects
designed for human potential



Rice Public Library

April 24, 2019

Introductions



Scott Simons - Principal

Ryan Kanteres - Project Architect

Seth Wilshultz - Project Manager



Michael Lassel - Principal

Sarah Hourihane - Project Architect

Michal Kaleta - Project Manager



Evening Goals

1. Provide Update
2. Discuss Community Needs
3. Explore Community Engagement

History of Project

Rice Public Library Timeline

1888 - Construction of Rice Public Library

1979 - RPL added to the National Historic Register

1988 - 1990 - Rice Library purchases Taylor Building, renovates and opens annex

2011 - Cohen Associates report assessing program needs issued

2015 - Lassel Architects report assessing program needs issued

2015 - Lassel Architects develops conceptual design of a new library off-site

2017 - The Town of Kittery votes to rehabilitate and add to existing library building

2018 - Founding of Library Building Committee to explore expansion options

Assessment of Existing Conditions



Pamela Hawkes - Historic Preservation Architect

Programming Interviews and Assessment

Library Staff Interviews

Feb 06, 2019

Friends of the Library Interviews

Feb 06, 2019

Kittery Schools Interviews

Feb 13, 2019

Library Board Interviews

Feb 26, 2019

Kittery Community Center Interviews

Feb 26, 2019

Kittery Foreside Group Interviews

Feb 26, 2019

Teen User Interviews

Feb 26, 2019





garden
outdoor event space



multi-use spaces



bright reading spaces



meeting room
teleconference and support



charging cafe



fabrication lab
maker space
stem learning



Honor Historically Significant Structures



Preserve Significant Features



Separation
Provide a clear delineation between new and old



Separation
Provide a clear delineation between new and old



Scale
Develop a building mass which is compatible with the existing context



Scale
Develop a building mass which is compatible with the existing context

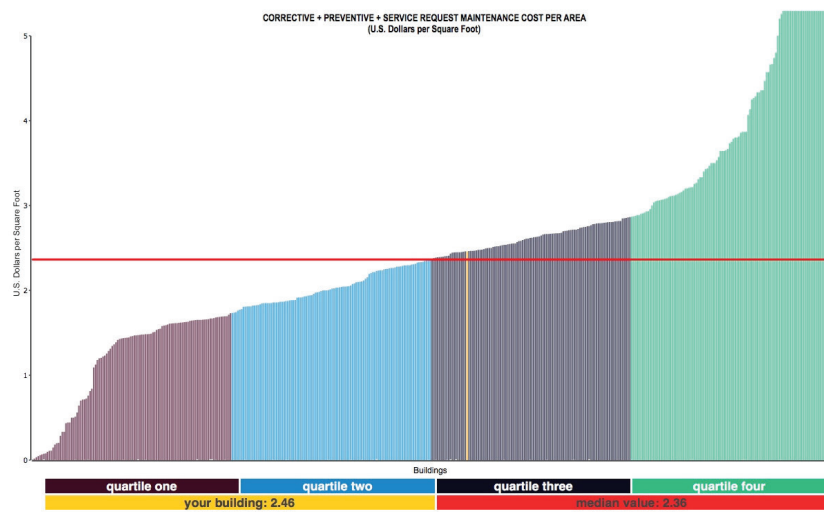

operating costs
life cycle costs



daylighting

Annual Energy Consumption Intensities by End Use and Building Function

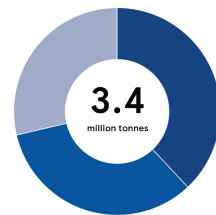
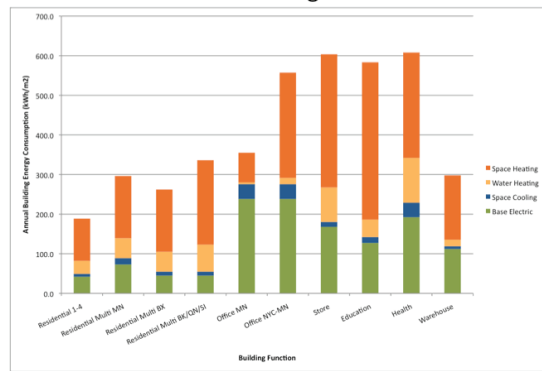

carbon footprint
energy usage



site design
open space / shading
storm water impact



indoor environmental quality



healthy materials

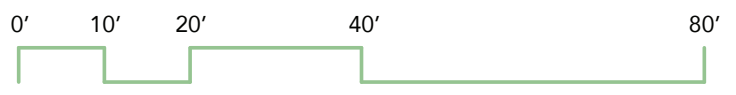
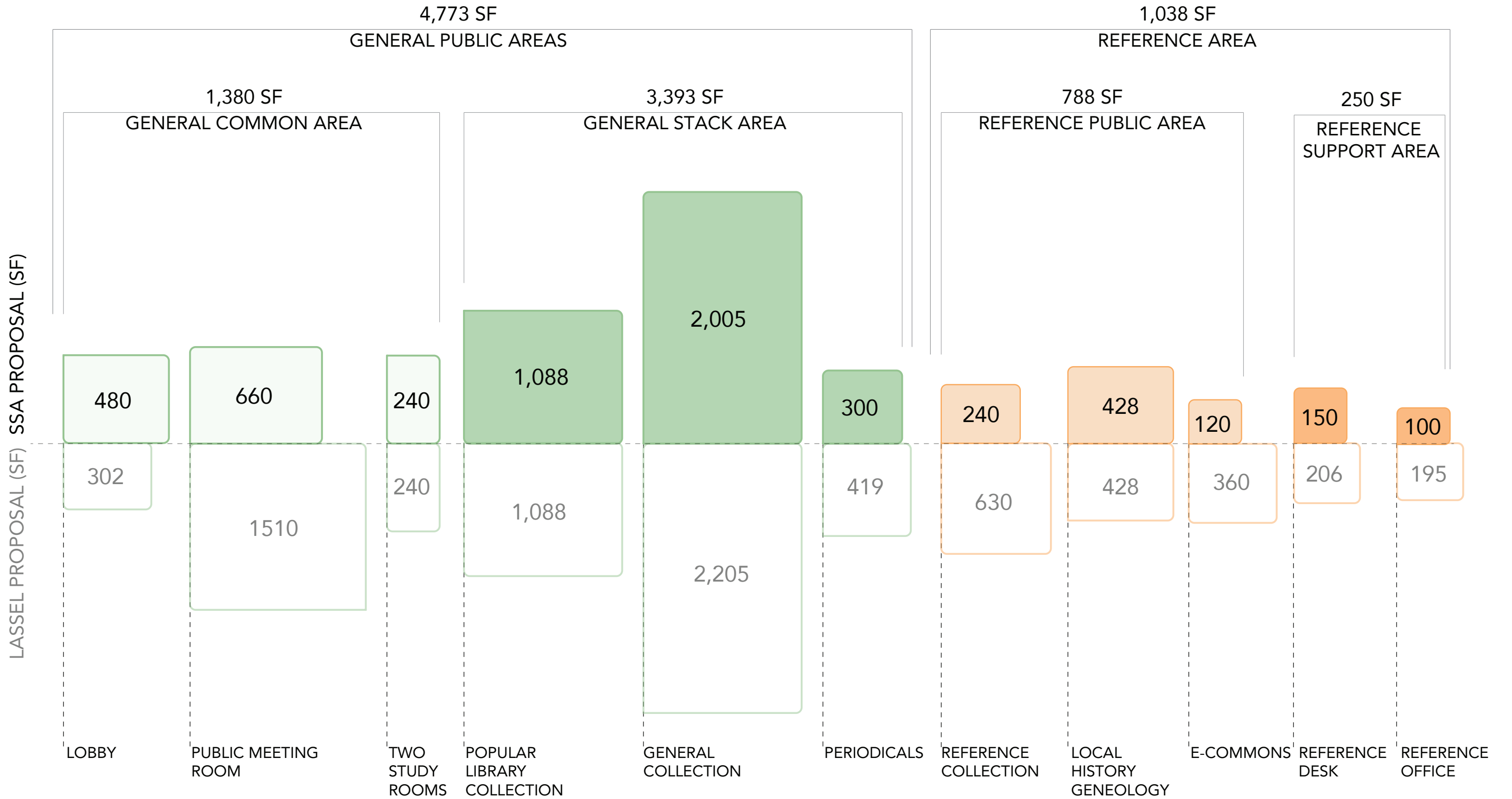

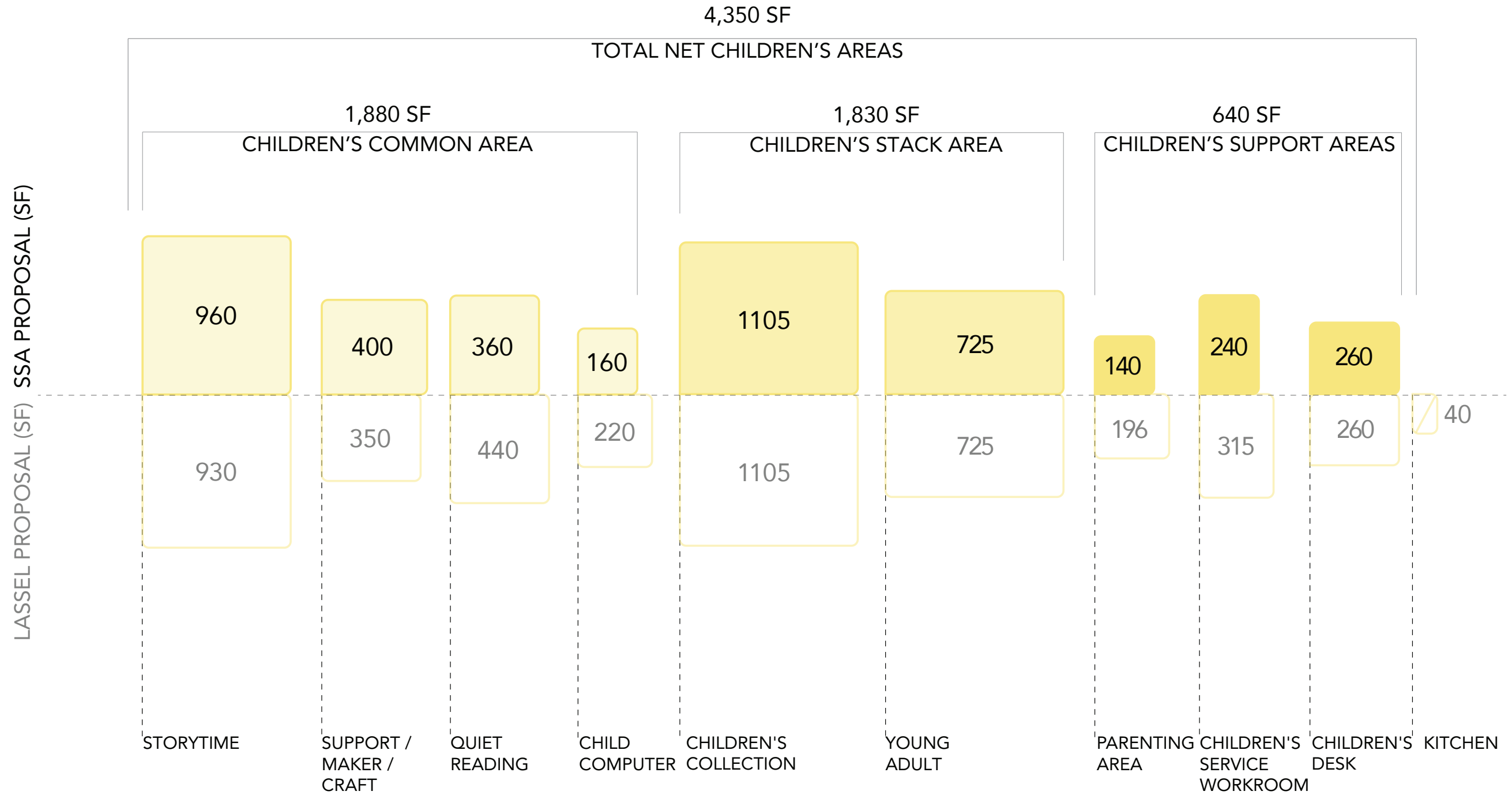

LASSEL PROPOSAL (SF) SSA PROPOSAL (SF)

2,155 SF
GENERAL SERVICE AREAS

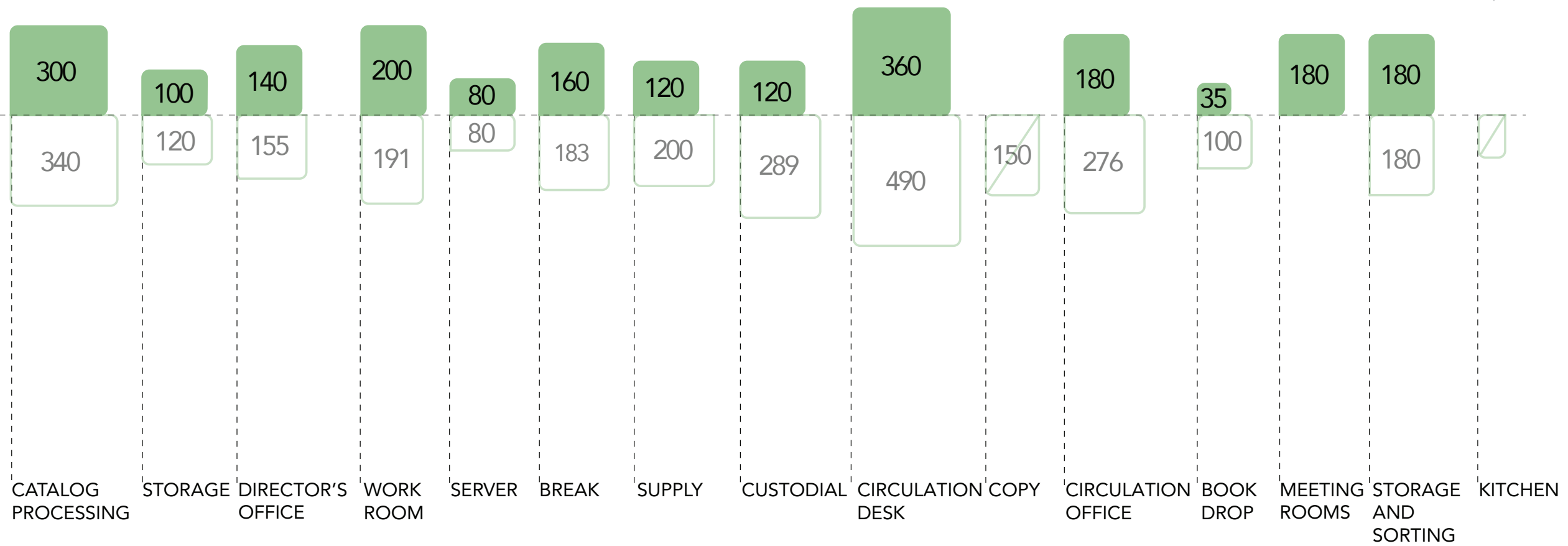

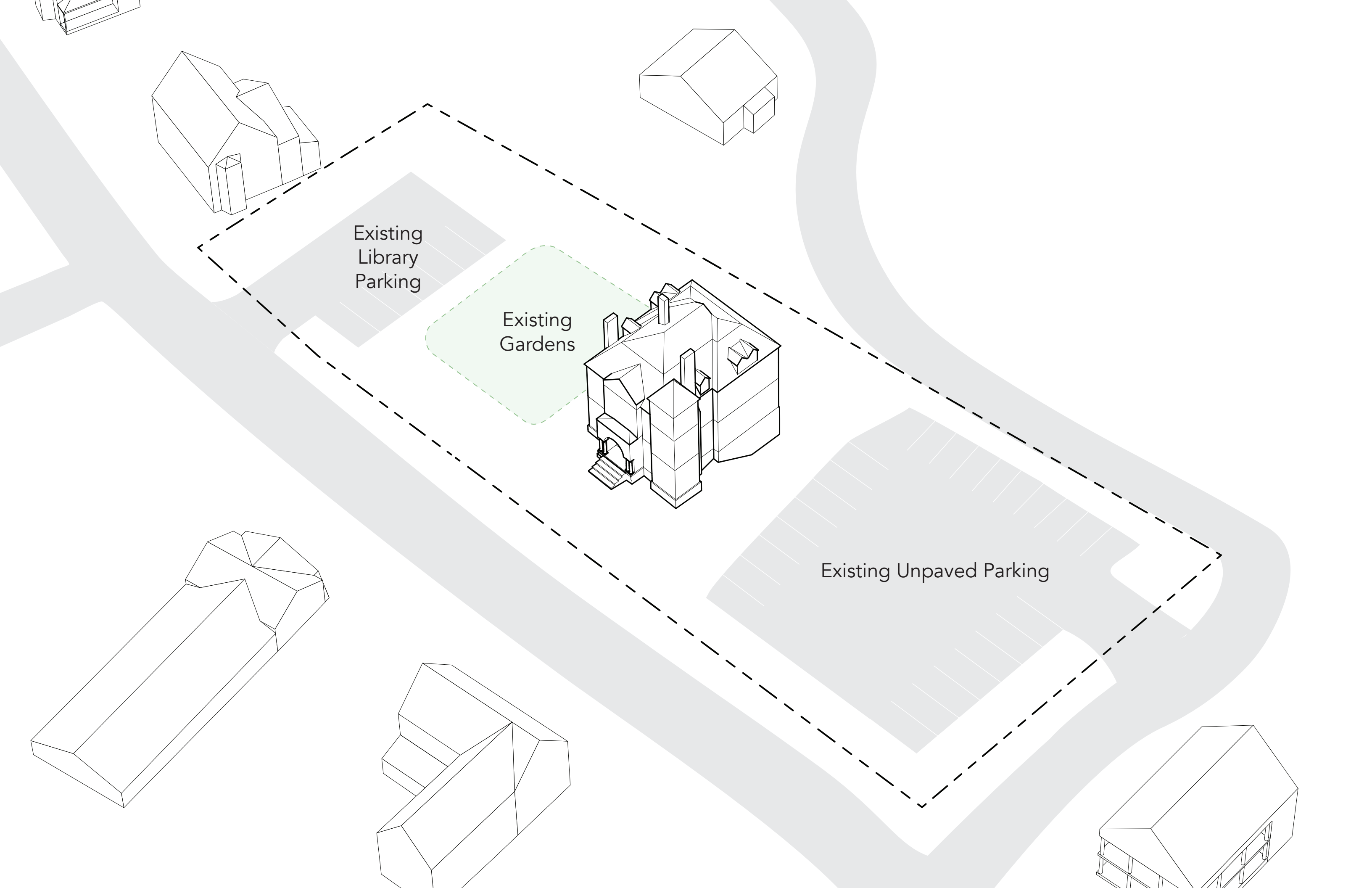

Existing
Library
Parking

Existing
Gardens

Existing Unpaved Parking

North Scheme -
Step 1 - Required Square Footage

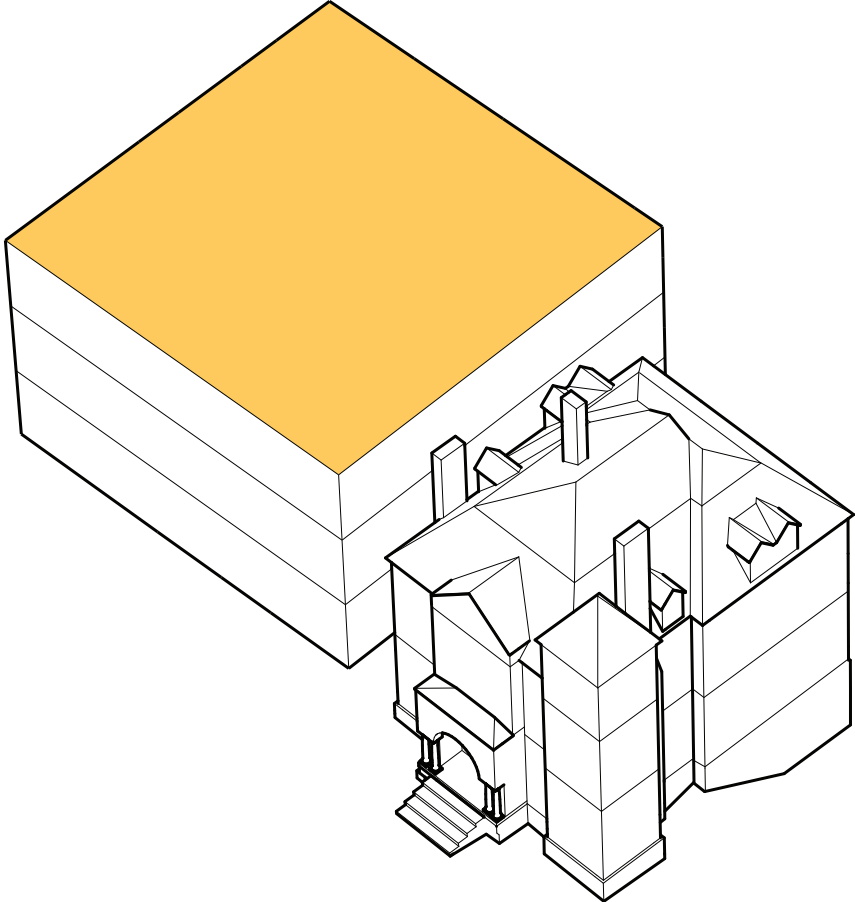

North Scheme -
Step 2 - Scaling to Historic Building

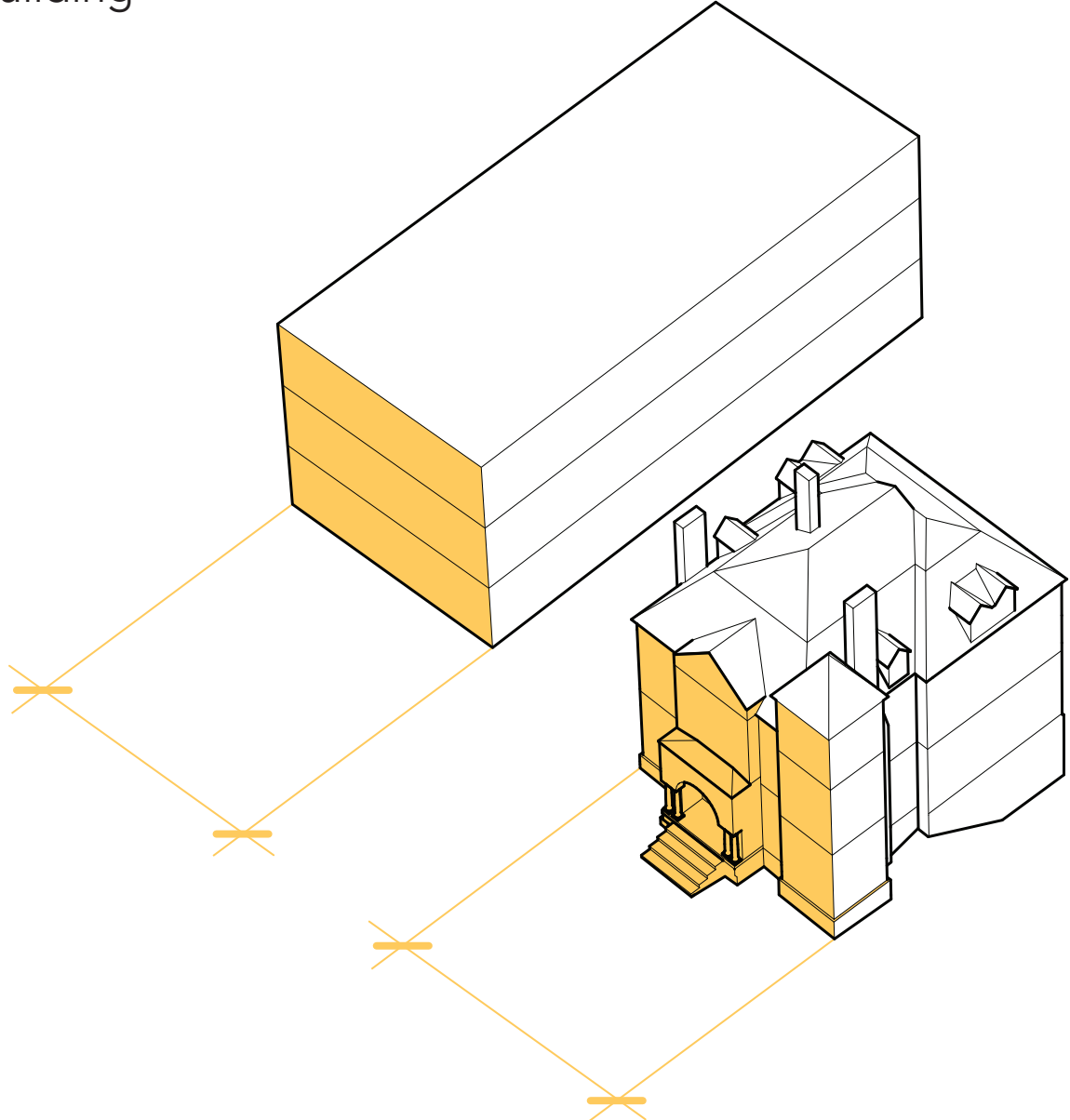

North Scheme -
Step 3 - Reducing Street Frontage

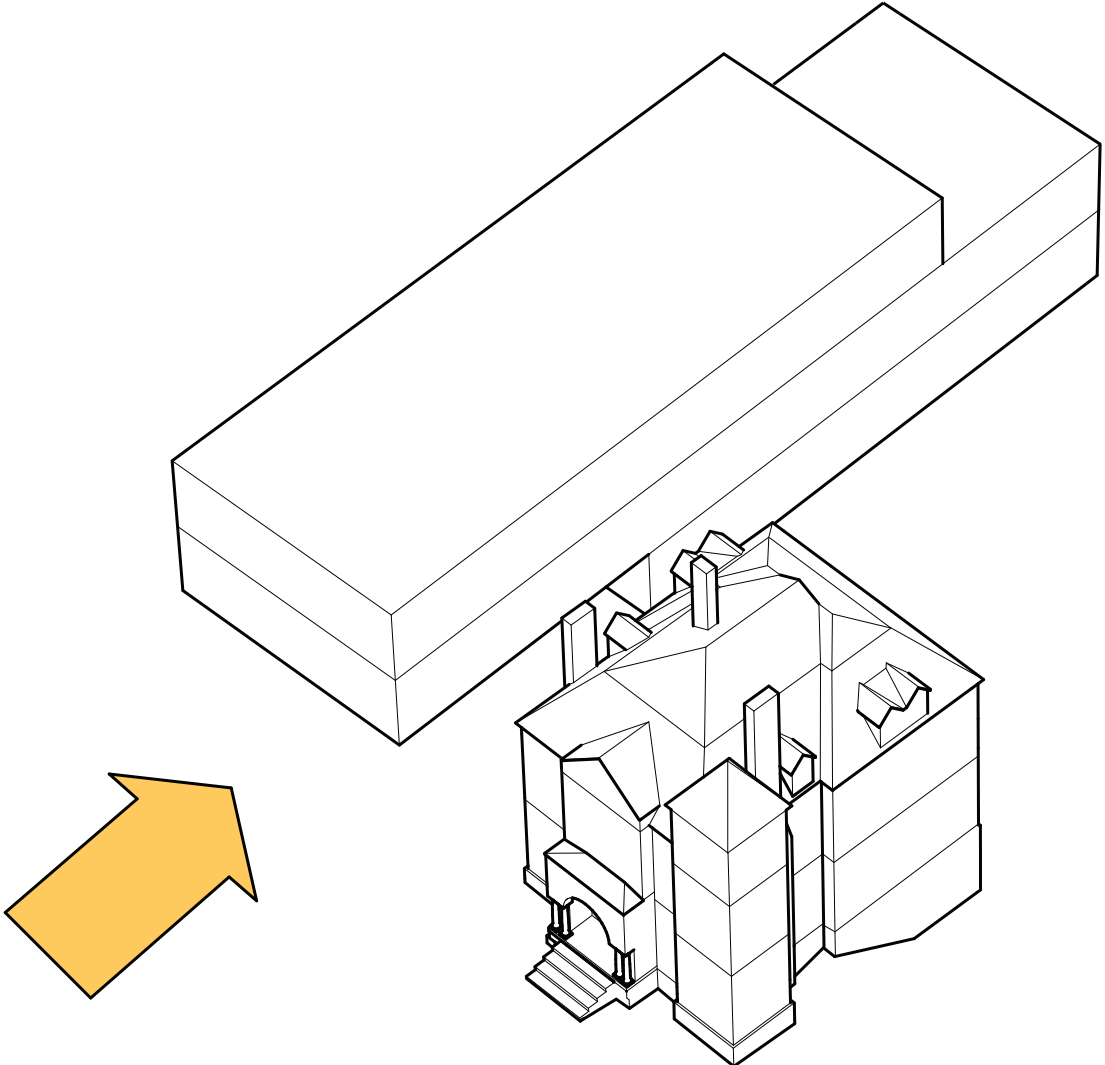

North Scheme -
Step 4 - Connecting to South Parking Lot

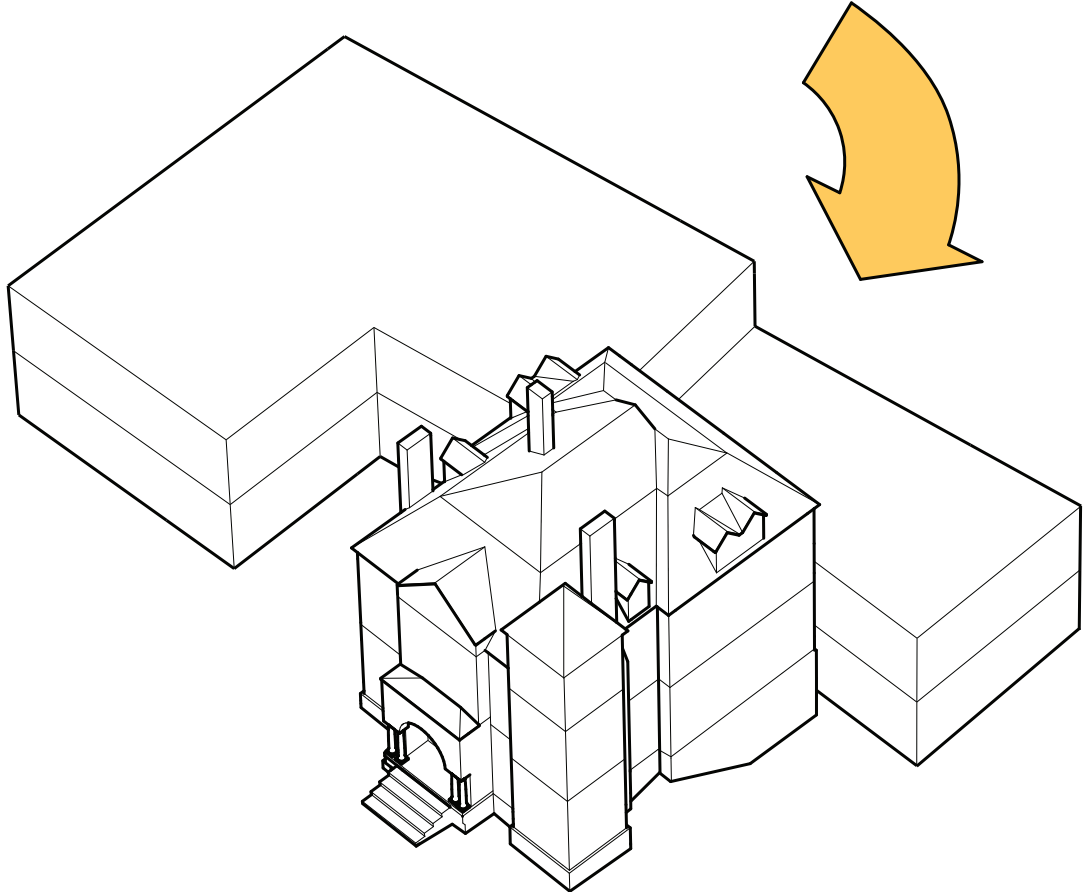

North Scheme -
Step 5 - Connecting to Community

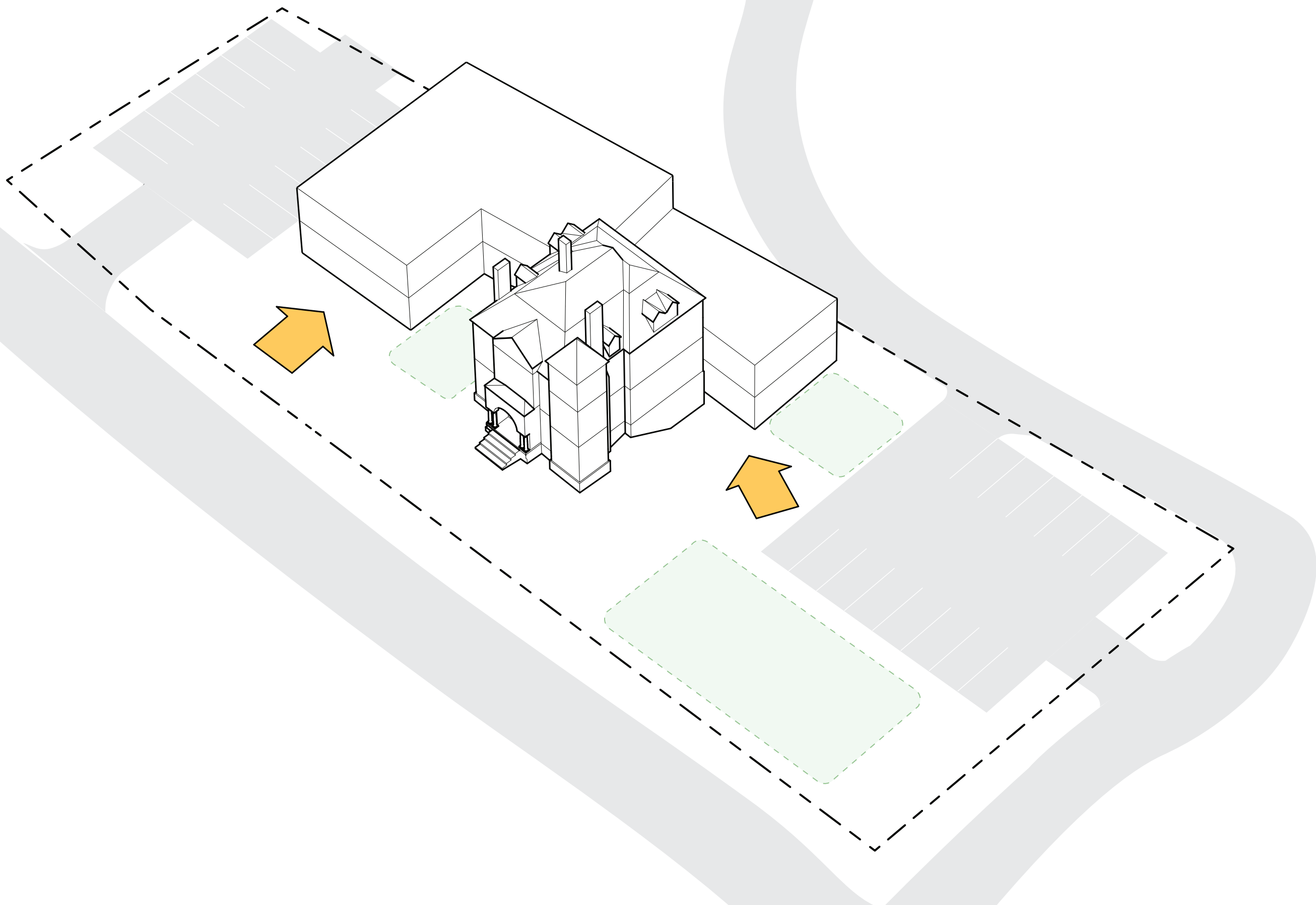

North Scheme - Site Plan

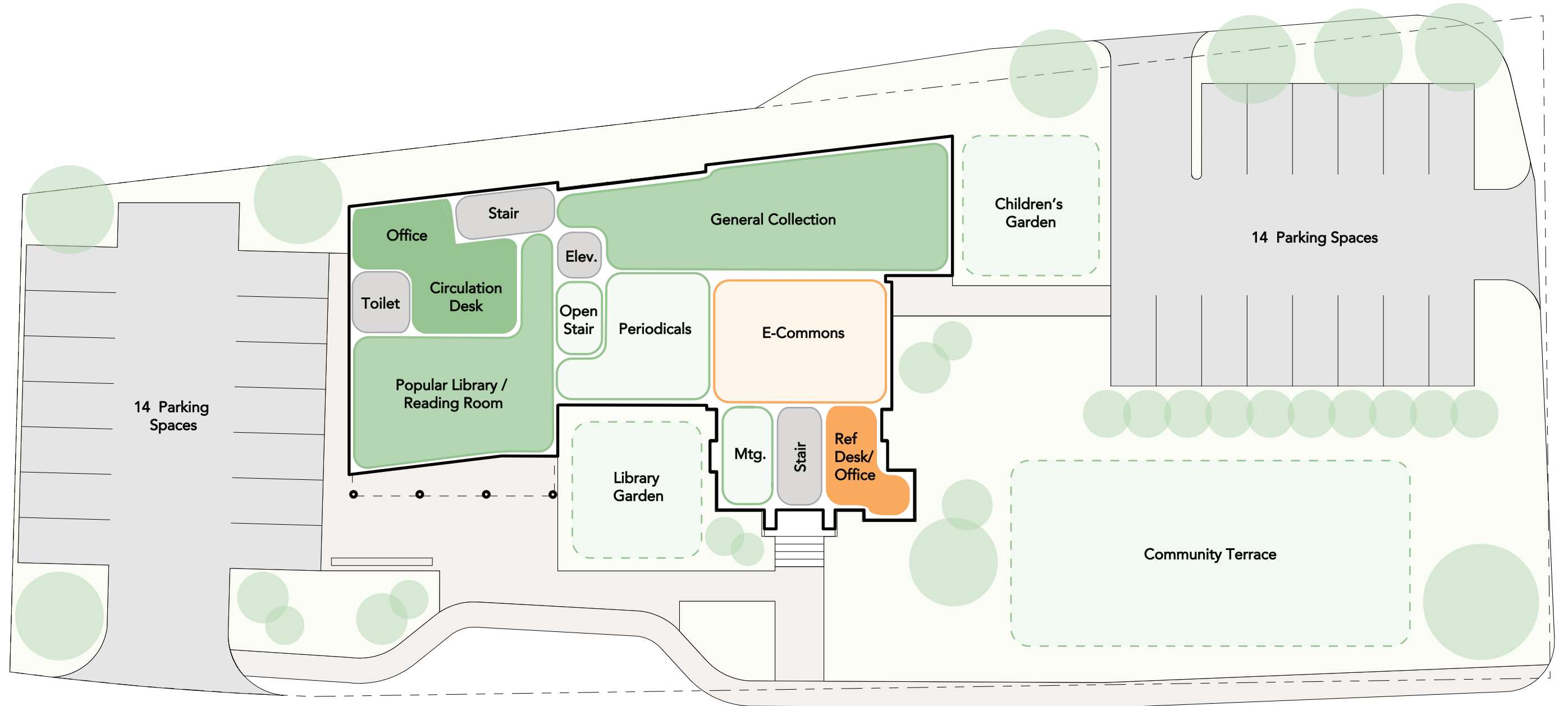

North Scheme - Diagrammatic Section

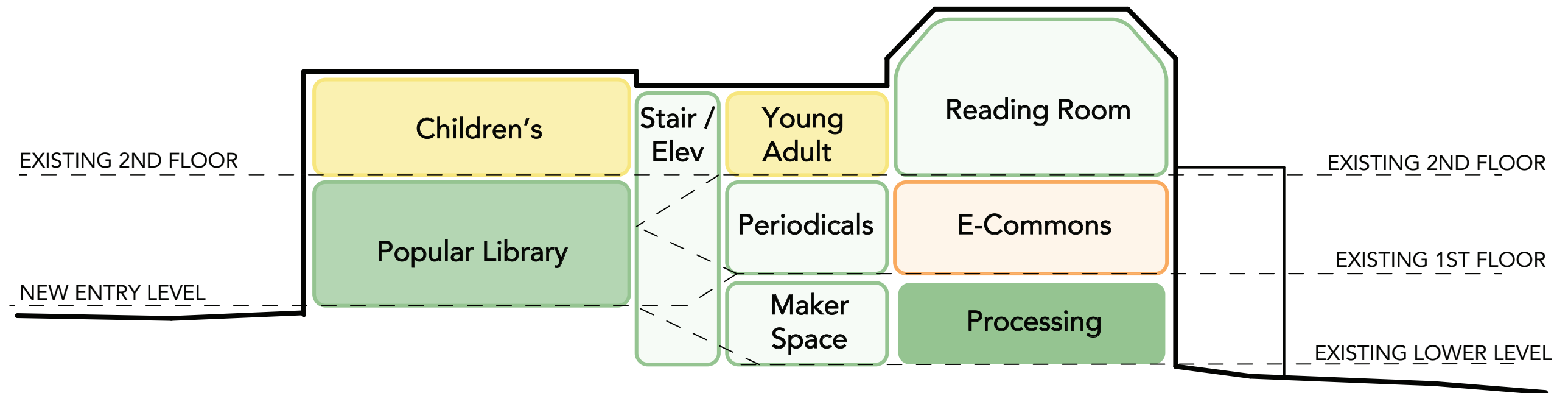

North Scheme - Lower Level Floor Plan

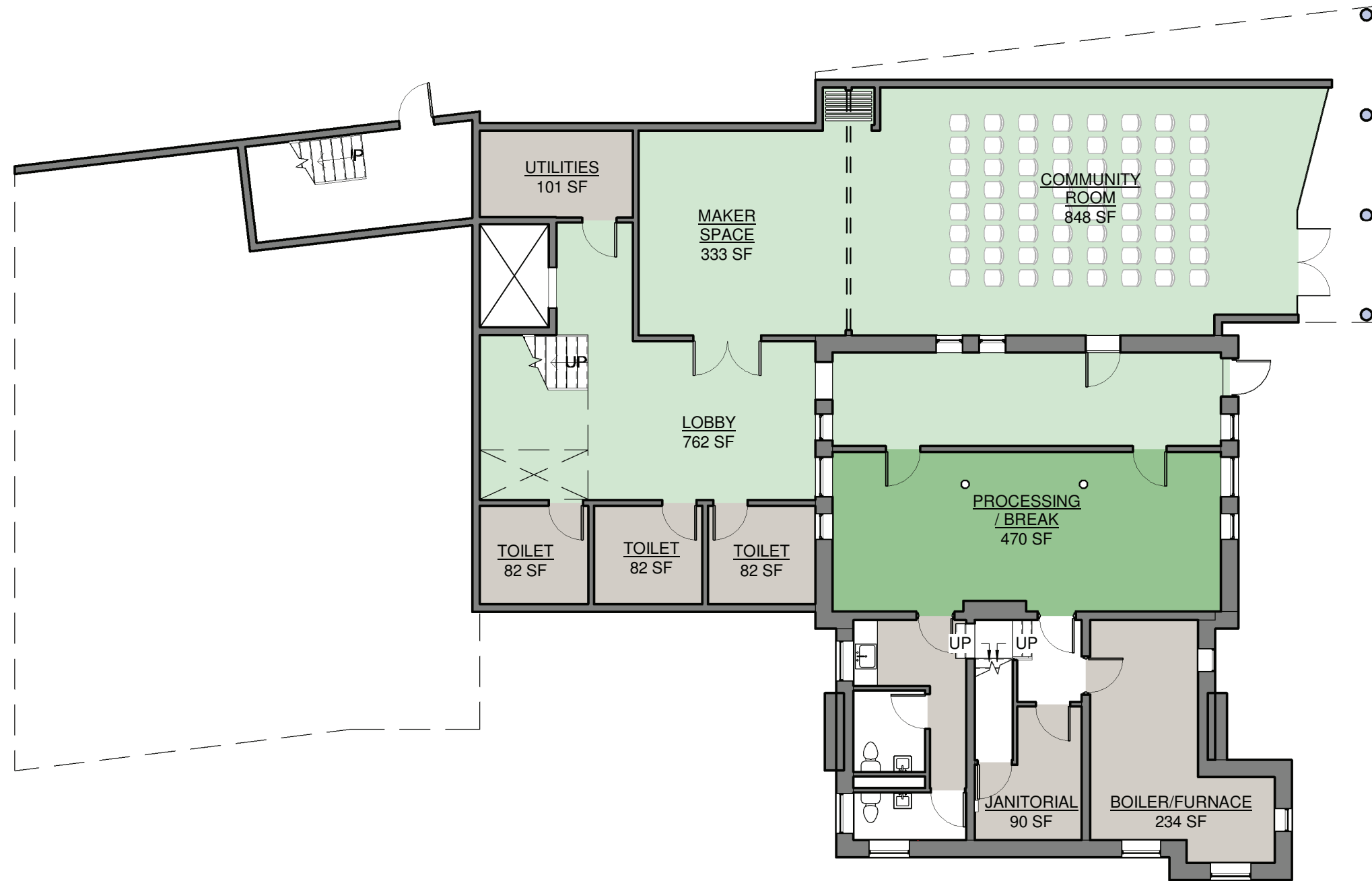

North Scheme - First Floor Plan

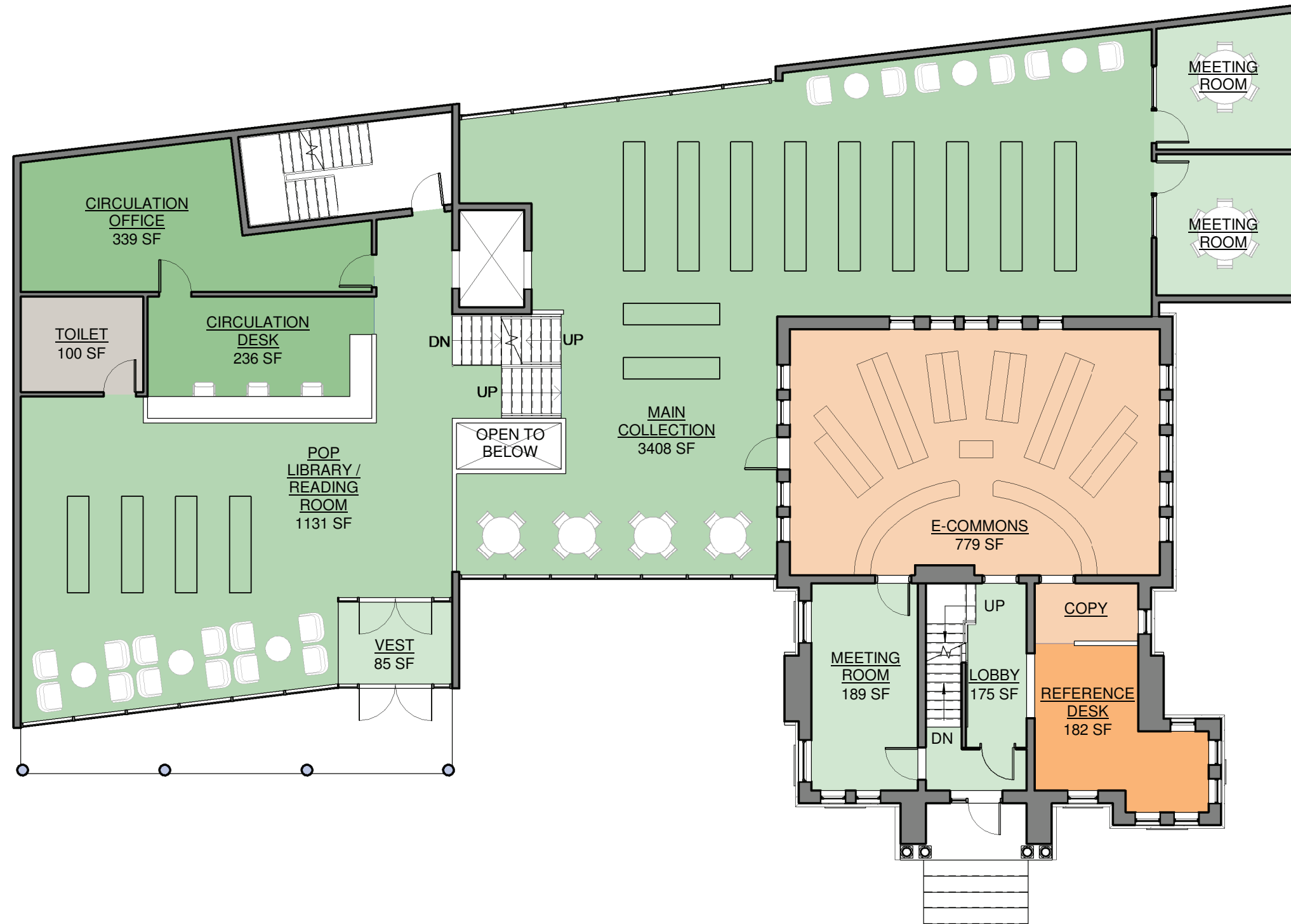

North Scheme - Second Floor Plan



South Scheme -
Step 1 - Required Square Footage

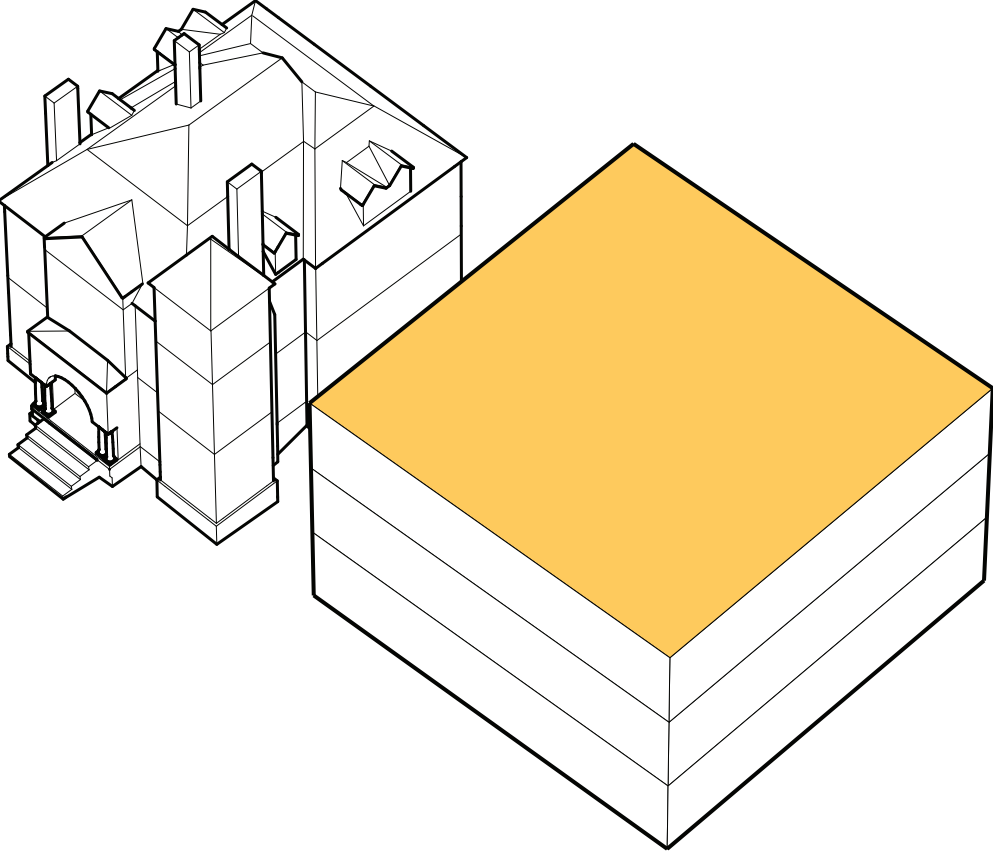

South Scheme -
Step 2 - Moving Mass Down the Site

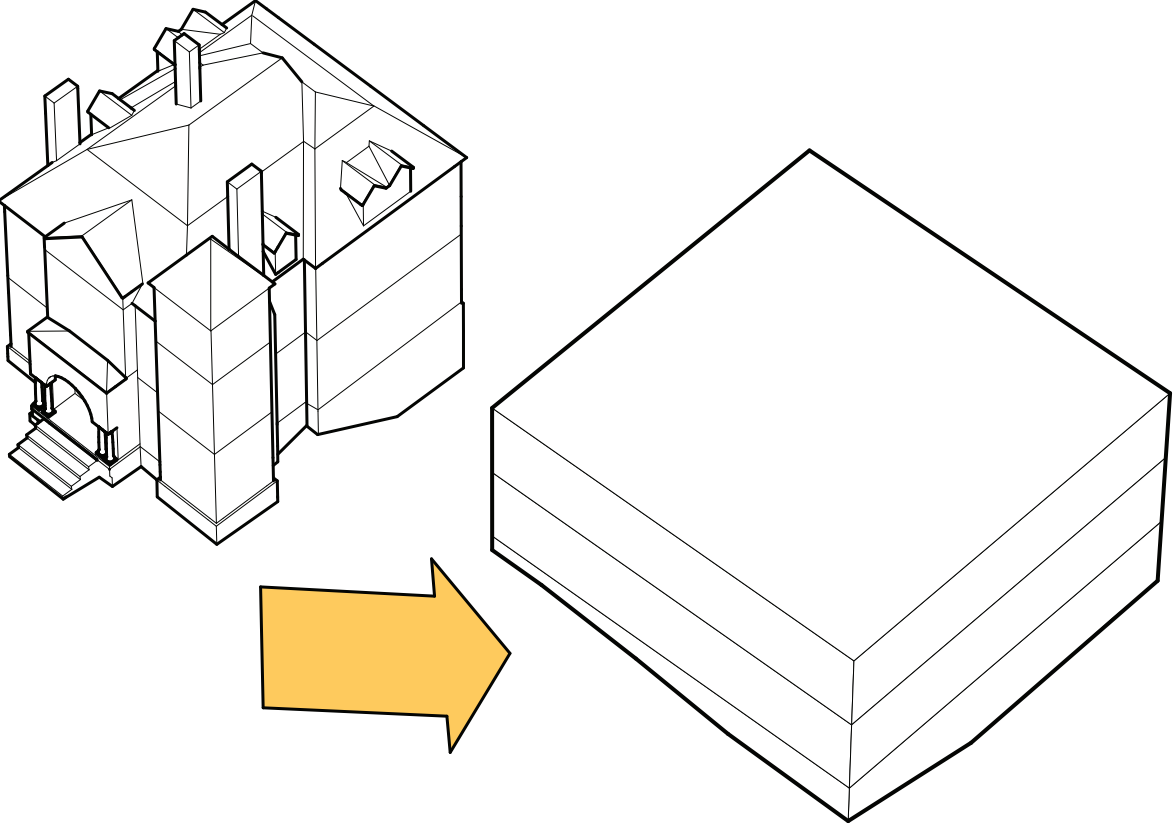

South Scheme -
Step 3 - Connecting to Historic Building

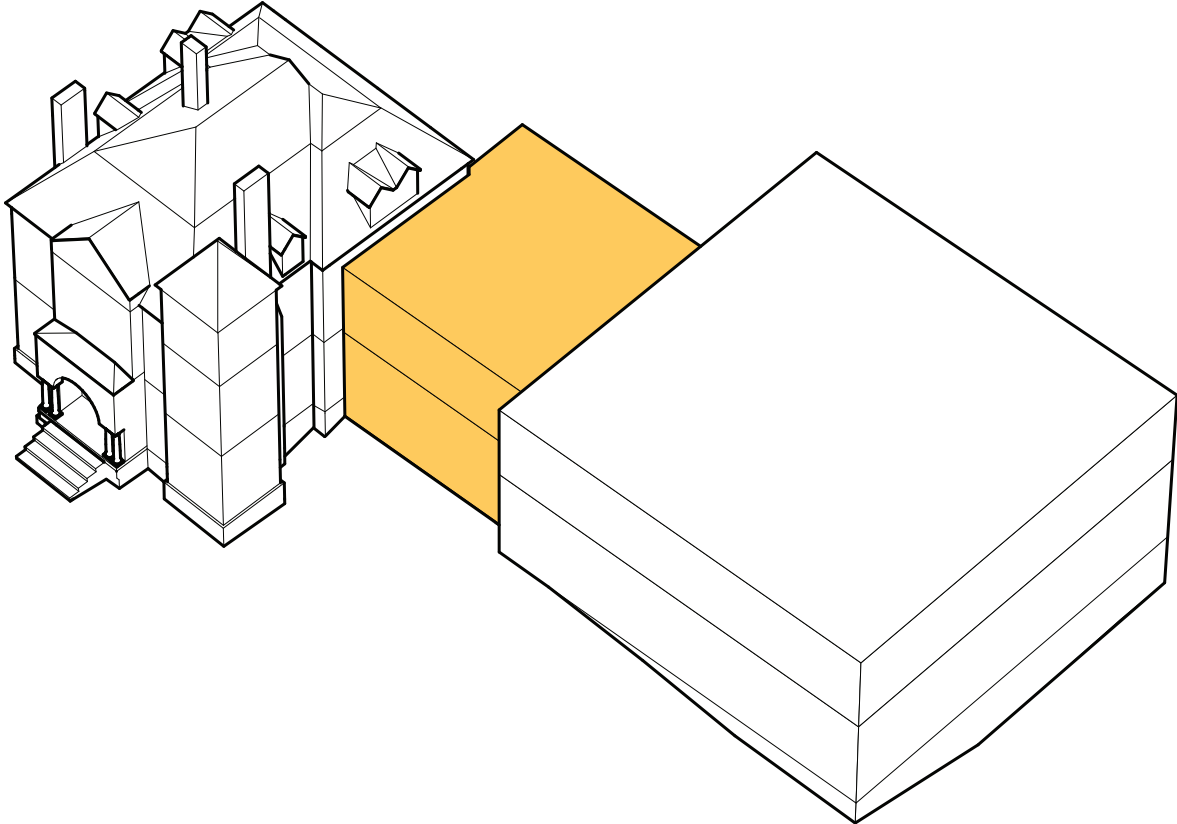

South Scheme -
Step 4 - Scaling to Historic Building

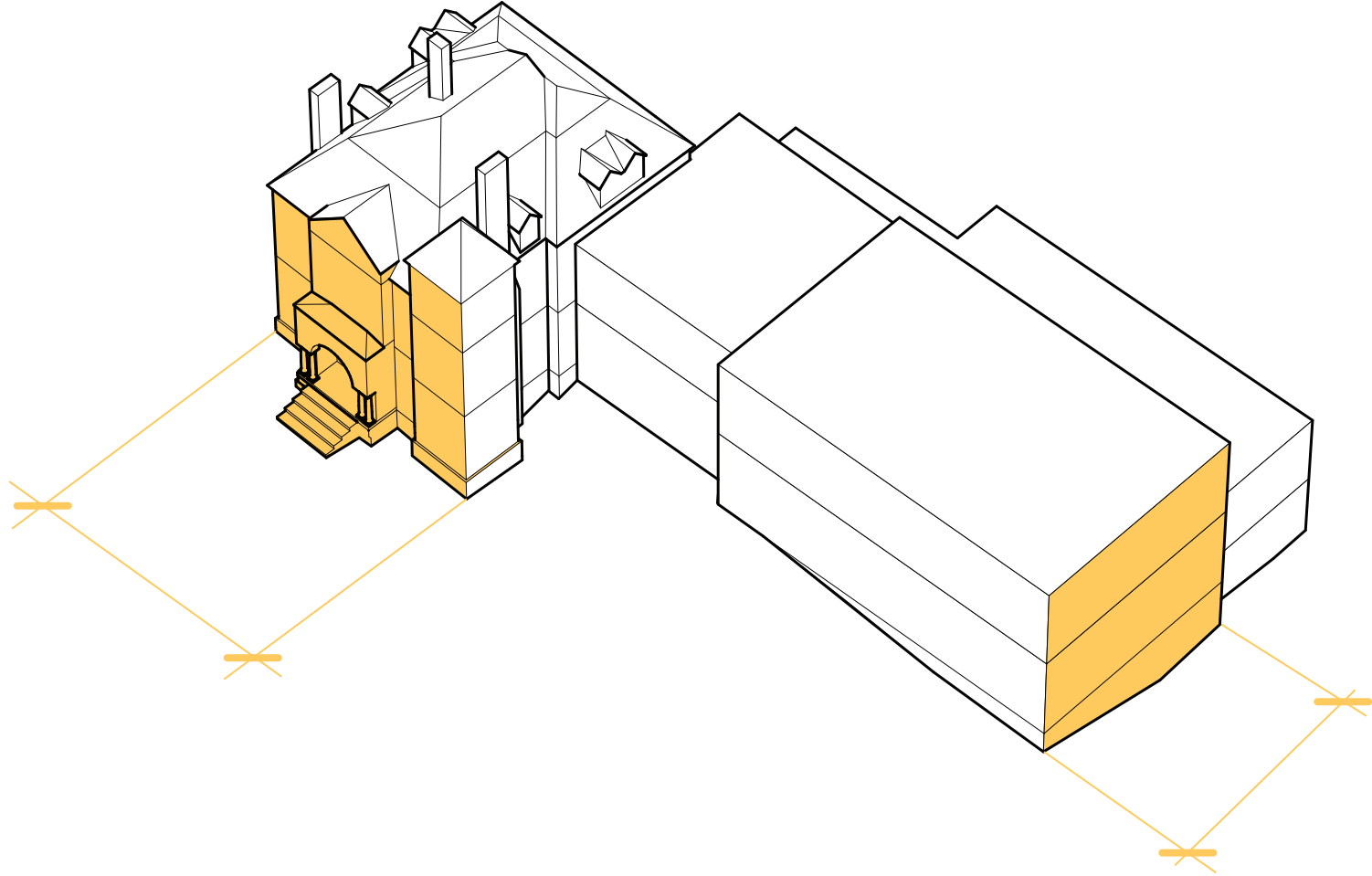

South Scheme -
Step 5 - Connecting to Community

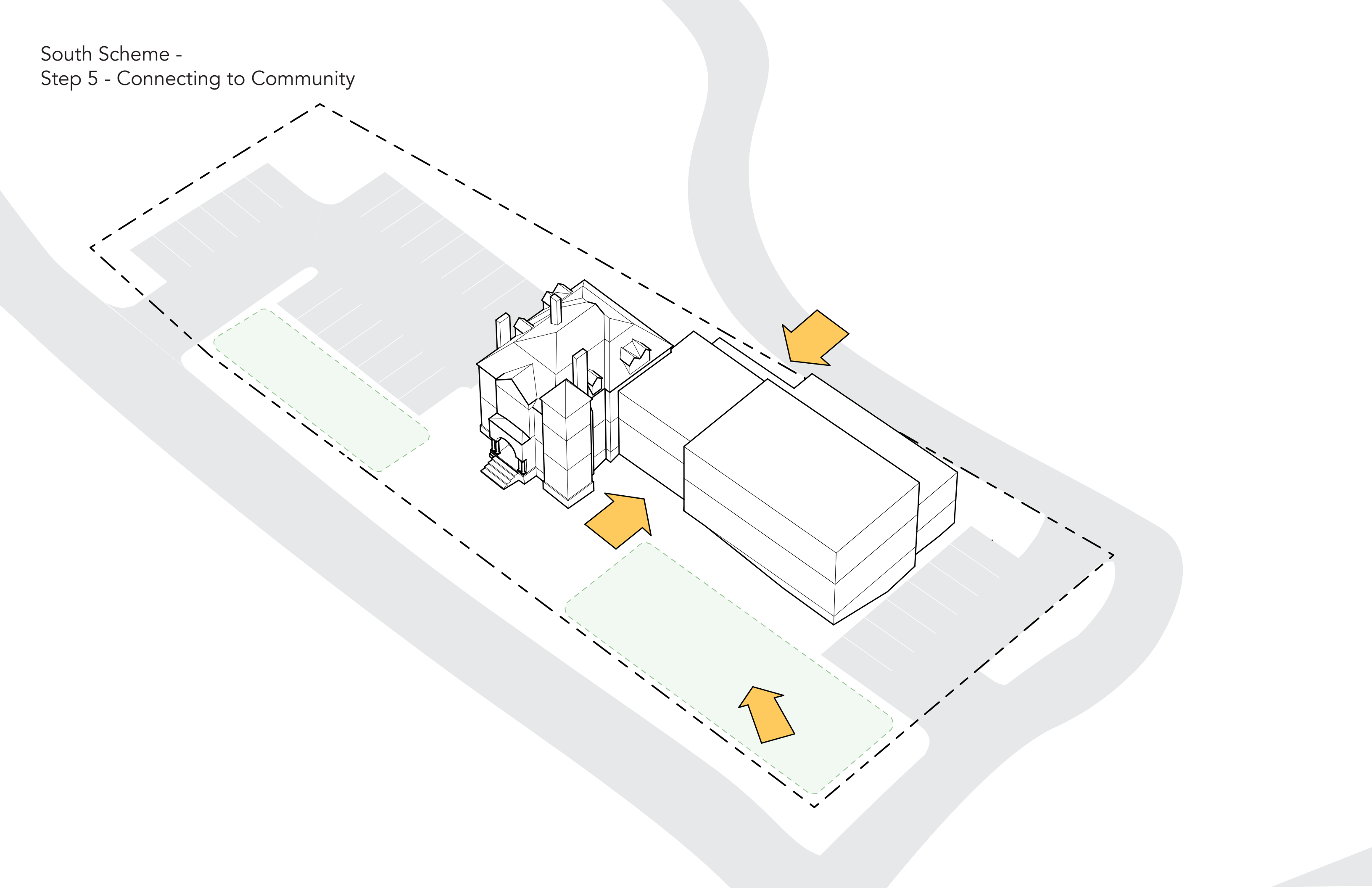

South Scheme - Site Plan

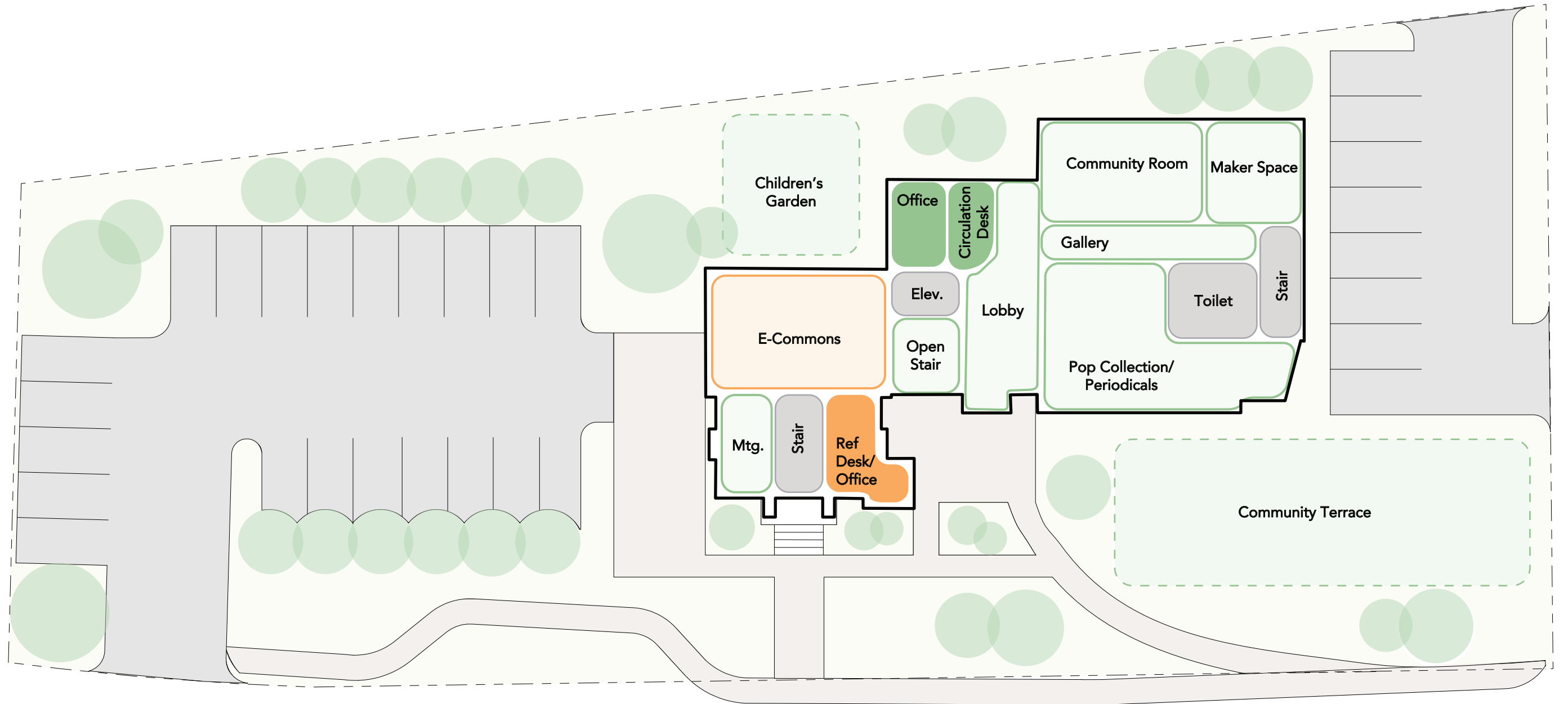

South Scheme - Diagrammatic Section

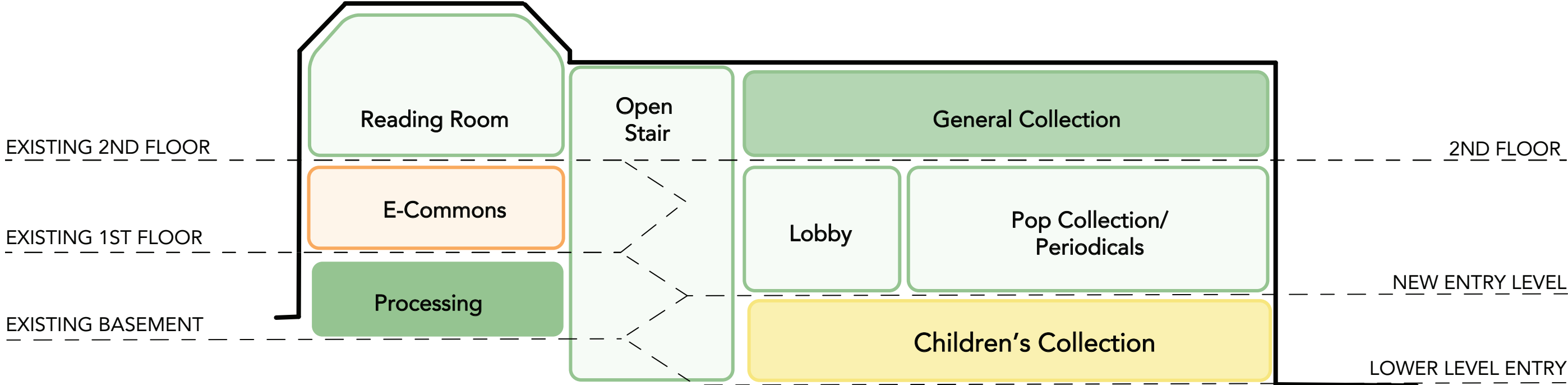

South Scheme - Lower Level Floor Plan



South Scheme - First Floor Plan

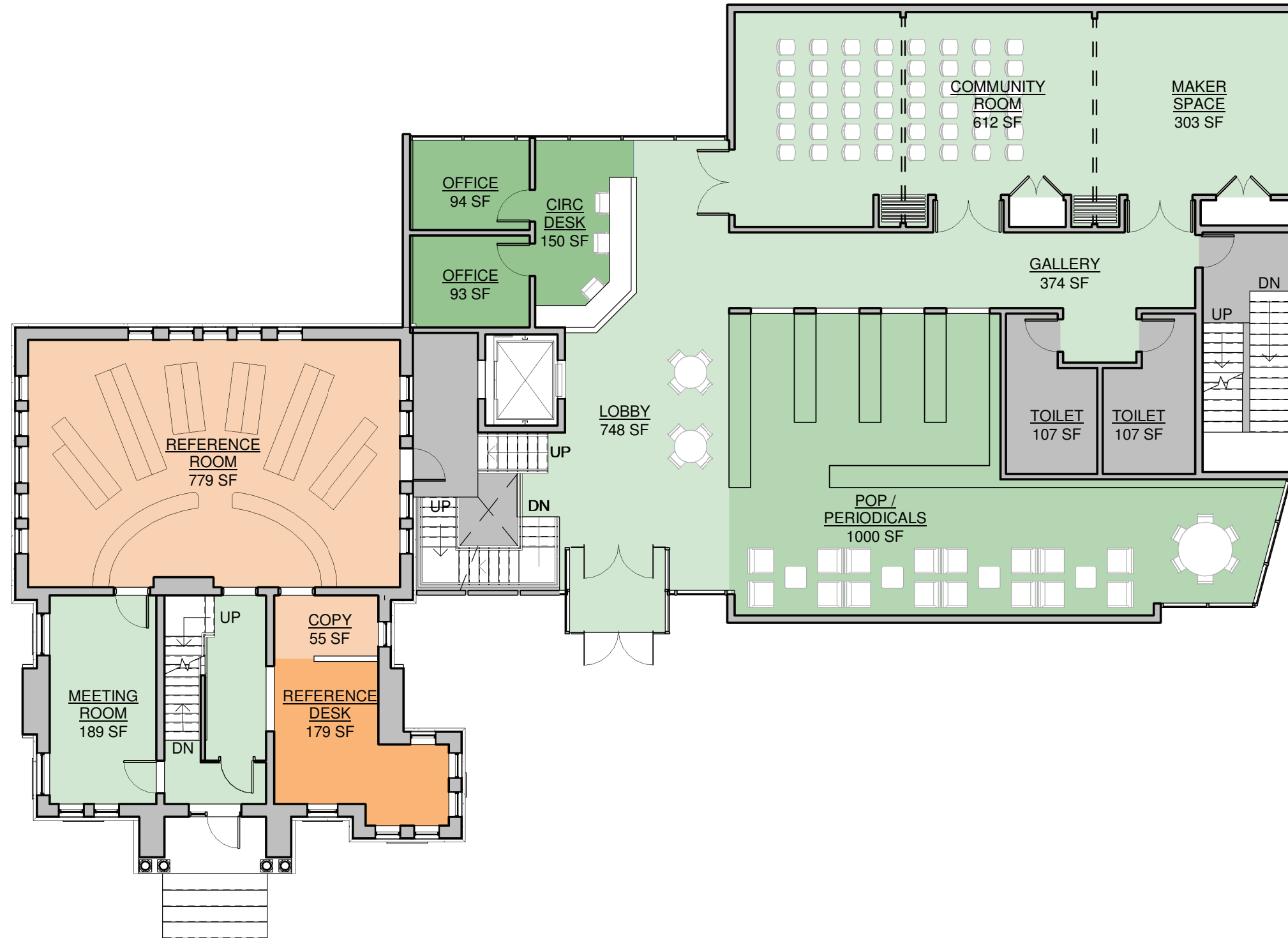

South Scheme - Second Floor Plan

